

Double action controller with analogue output 1/4 DIN - 96 x 96 mm gammadue® series Q3 line



Analogue control within everyone's reach

Including Auto/Man selection
and digital inputs for external
activation of:

- Stored Setpoints
 - Timer function
 - Setpoint programmable profile
- the gammadue® Q3 line
is simple, yet is suitable to satisfy
almost all control needs:
- time proportioning
 - analogue
 - single or double action
 - valve drive

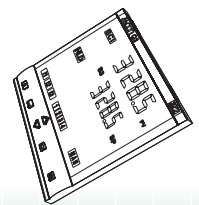
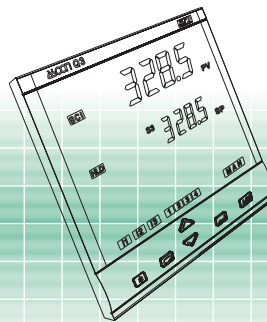
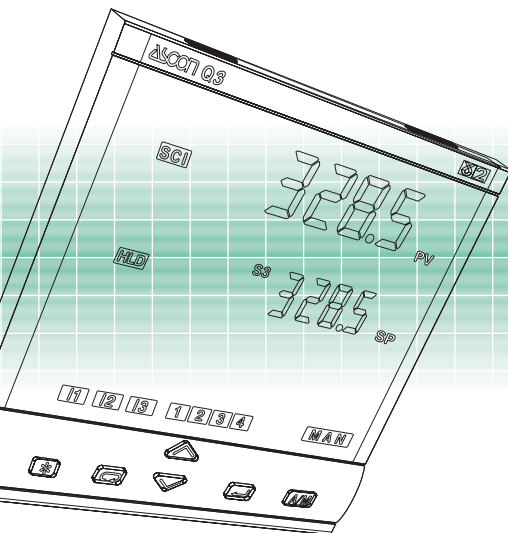

E

ISO 9001 Certified

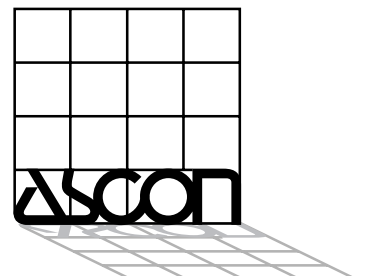

Technical data

Features at env. 25°C	Description				
Total configurability	From keypad or serial communications, the user selects: type of input - associated functions and corresponding outputs - type of control algorithm - type of output and safe conditions - alarm types and functionality - control parameter values				
PV input for signal ranges see table 1)	Common characteristics	A/D converter with 50,000 points Update measurement time: 0.2 s Sampling time: 0.5 s Input shift: -60...+60 digit Input filter: 1...30 s (OFF= 0)			
	Accuracy	0.25% ±1 digit (T/C and RTD) 0.1% ±1 digit (mA and mV)	Between 100 and 240V~error is minimal		
	Resistance thermometer (for ΔT: R1+R2 must be <320Ω)	Pt100Ω at 0°C (IEC 751) °C/°F selectable	2 or 3 wires connection Burnout (with any combination)		
	Thermocouple	L, J, T, K, S, R, B, N, E, W3, W5 (IEC 584) °C/°F selectable	Internal cold junction compensation with NTC Error 1°C/20°C ± 0.5°C Burnout		
	DC input (current)	0/4...20mA, 2.5Ω ext. shunt Rj >10MΩ	Burnout. Engineering units, floating decimal point, configurable Low Range -999...9,999 High Range -999...9,999 100 digits minimum		
	DC input (voltage)	0/10...50mV, Rj >10MΩ	Input drift: <0.1%/20°C T _{Env} <5μV/10Ω line resist.		
Auxiliary inputs	Remote Setpoint (option) Not isolated accuracy 0.1%	Current 0/4...20mA Rj = 30Ω Voltage 1-5/0-5/0-10V Rj = 300kΩ	Bias in engineering units and ±range Ratio from -9.99...+99.99 Local + Remote		
	CT current transformer	50 or 100mA input hardware selectable	Current visualization 10...200 A with 1A resolution and Heater break alarm		
Digital inputs 3 logic	The closure of the external contact produces any of the following actions	Auto/Man mode change, Local/Remote Setpoint mode change, Stored Setpoints activation, keypad lock, measure hold Timer activation, program run/hold (if options installed)			
Operating modes	1 single or double action P.I.D. loop or ON/OFF with 1, 2 or 3 alarms				
Control mode	Algorithm	P.I.D. with overshoot control or ON/OFF P.I.D. with valve algorithm, for controlling motorised positioners			
	Proport. band (P)	0.5...999.9%	User Enabled/ Disabled		
	Integral time (I)	0.1...100.0 min			
	Derivative time (D)	0.01...10.00 min			
	Error dead band	0.1...10.0 digit			
	Overshoot control	0.01...1.00	Single action PID algorithm		
	Manual reset	0.0...100.0%			
	Cycle time (Time proportioning only)	1...200 s			
	Control output high limit	10.0...100.0%			
	Soft-start output value	0.1...100.0%	User Enabled/ Disabled	ON/OFF algorithm	
	Output safety value	0.0...100.0% (-100.0...100.0% for Heat/Cool)			
	Control output hysteresis	0.1...10.0%			
	Dead band	-10.0...10.0%			
	Relative cool gain	0.1...10.0	Double action PID algorithm (Heat/Cool) with overlap		
Cycle time (Time proportional only)	1...200 s				
Cool output high limit	10.0...100.0%				
Cool output hysteresis	0.1...10.0%				
Motor travel time	15...600 s	Valve PID algorithm without feedback potentiometer			
Motor minim. step	by 0.1...5.0%				

Input type	Scale range
RTD Pt100 IEC751	-99.9...300.0 °C
	-99.9...572.0 °F
RTD Pt100 IEC751	-200...600 °C
	-328...1,112 °F
TC L Fe-Const DIN43710	0...600 °C
	32...1,112 °F
TC J Fe-CU45% NI IEC584	0...600 °C
	32...1,112 °F
TC T Cu-CuNi	-200...400 °C
	-328...752 °F
TC K Cromel-Alumel IEC584	0...1,200 °C
	32...2,192 °F
TC S Pt10% Rh-Pt IEC584	0...1,600 °C
	32...2,912 °F
TC R Pt13% Rh Pt IEC584	0...1,600 °C
	32...2,912 °F
TC B Pt30% Rh Pt 6% IEC584	0...1,800 °C
	32...3,272 °F
TC N Nicrosil-Nisil IEC584	0...1,200 °C
	32...2,192 °F
TC E Ni10% CR CuNi IEC584	0...600 °C
	32...1,112 °F
TC NI NiMo18%	0...1,100 °C
	32...2,012 °F
TC W3%Re W25%Re	0...2,000 °C
	32...3,632 °F
TC W5%Re W26%Re	0...2,000 °C
	32...3,632 °F
0/4...20 mA	Configurable engineering units mA, mV, V, bar, psi, Rh, ph
0/10...50 mV	
mV Custom scale	On request

Table 1: PV input

Special functions

To improve the instrument performance and to reduce the wiring and installation costs, two special functions are available:

- Start-up

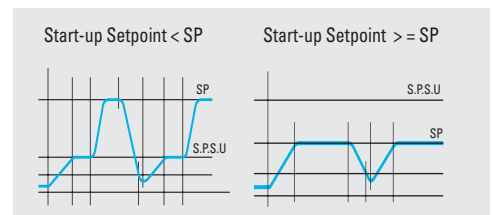

- Timer

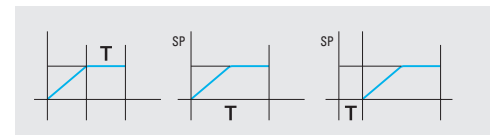

The use of these functions avoids additional device installation (e.g. external timer), therefore allowing a significant costs reduction.

Moreover there are:

- **Keypad lock/unlock** function, to avoid incorrect operator actions
- **Outputs lock/unlock** function, at any moment it is possible to stop the control action, but not the process variable display, without switching-off the power supply.

Technical data

Features at env. 25°C	Description		
OP1-OP2 outputs	SPST relay N.O., 2A/250V~ for resistive load Triac, 1A/250V~ for resistive load		
OP3 output	SPDT relay N.O., 2A/250V~ for resistive load		
OP4 output	SSR drive not isolated: 0/5V-, ± 10%, 30mA max. SPST relay N.O., 2A/250V~ for resistive load		
OP5 (option) analogue control output	Control or PV/SP retransmission	Galvanically isolated: 500V~/1min. Resolution: 12 bit Accuracy: 01% In current: 0/4...20mA, 750Ω/15V max.	
AL1- AL2 - AL3 alarms	Hysteresis	0.1...10.0%	
	Action	Active high	Action type
		Active low	Deviation threshold ± range Band threshold 0...range Absolute threshold, whole range
		Special functions	Sensor break, Heater break and Loop break detection Acknowledge (latching), activation inhibit (blocking) Connected to Timer or program (if options installed)
Setpoint	Local	Up and down ramps 0.1...999.9 digit/min. (OFF=0) Low limit: from low range to high limit High limit: from low limit to high range	
	Local plus two stored (tracking or Stand-by)		
	Local and Remote		
	Local with trim		If option installed
	Remote with trim		
Programmable Setpoint (option)	1 program, 8 segments 1 initial and 1 end, from 1 to 9,999 cycles or continuous cycling (OFF) Start, stop, hold, etc. activated from the keypad, digital input and serial comm.s		
Special functions (options)	Timer	Automatic start at the power on, manual start by keypad, Digital inputs or serial comm.s Setting time: 1...9,999 s/min. Stand-by Setpoint: from Setpoint low limit to Setpoint high limit	
	Start-up	Start-up Setpoint: from Setpoint low limit to Setpoint high limit Hold time: 0...500 min. Control output high limit: 5.0...100.0%	
One-shot Fuzzy-Tuning	Depending on the process condition, the controller applies the best method	Step response Natural frequency	
Auto/Man selection	Standard with bumpless function, by keypad, digital input or serial communications		
Serial comm.s (option)	RS 485 isolated, Modbus/Jbus protocol 1,200, 2,400, 4,800, 9,600 bit/s, three wires		
Auxiliary power supply	+24V- ±20%, 30 mA max. for external transmitter supply		
Operational safety	Measure input	Detection of out of range, short circuit or sensor break with automatic activation of the safety strategies and alerts on display	
	Control output	Safety value: -100%...100%	
	Parameters	A non volatile memory stores for unlimited time all the configuration and parameter values	
	Password	Password to access the configuration and parameters data, keypad lock, outputs lock	
General characteristics	Power supply (fuse protected)	100-240~ (-15% + 10%) 50/60Hz or 24~ (-15% + 25%) 50/60Hz and 24V- (analogue) (-15% + 25%)	Power consumption 4W max.
	Safety	Compliance EN61010-1 (IEC 1010-1), installation class 2 (2,500V), pollution class 2, class II instrument	
	Electromagnetic compatibility	Compliance to the CE standards for industrial system and equipment	
	Approval UL and cUL	File E176452	
	Protection EN60529 (IEC529)	IP65 front panel	
Dimensions	1/4 DIN - 96 x 96, depth 110 mm, weight 470g approx.		

Electrical wirings

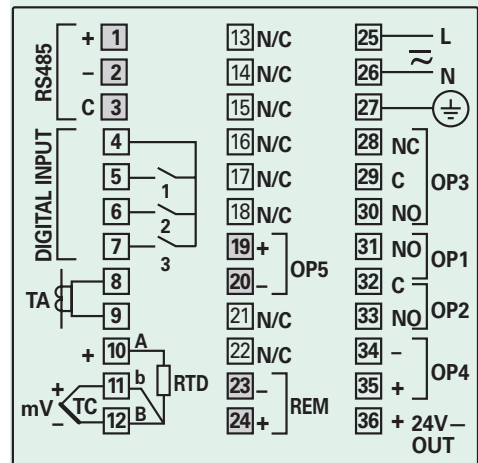

Fuzzy-Tuning

Two methods of tuning are available:

- **Auto-Tuning "one shot"**
- **Natural frequency "one shot"**

The **Fuzzy-Tuning** automatically selects one of the two methods which assure the best result for each condition.

The **Auto-Tuning** method works best on the step response basis.

When activated, if a deviation exists between the Setpoint and process variable larger than 5% of scale range, the controller modifies the output value. Then, in a short time, it calculates the PID parameters and the new algorithm is operational immediately.

The main advantages of this method are fast calculation and quick implementation.

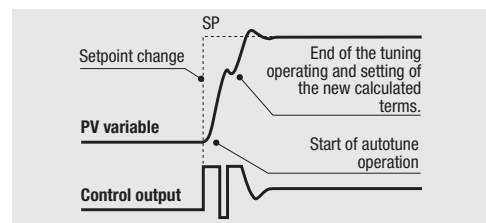

The **Natural frequency** method works best when the process variable is very near to the Setpoint.

When activated, it causes a process oscillation around the Setpoint value.

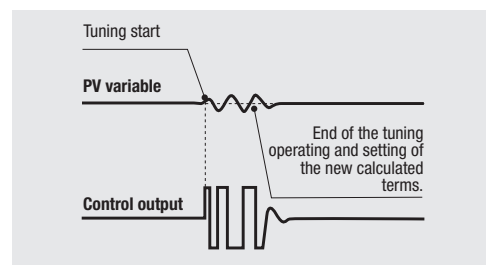

Ordering codes

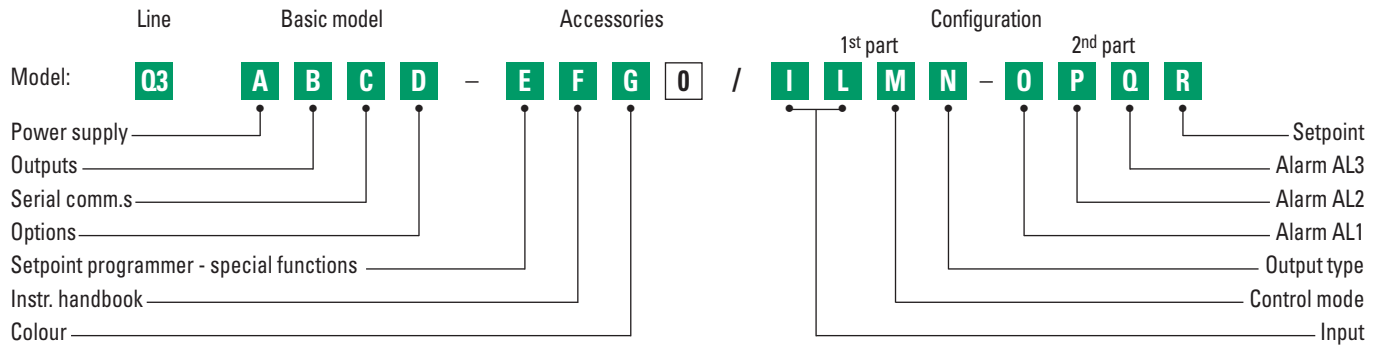

Power supply	A
100-240V~ (-15% +10%)	3
24V~ (-25% +12%) or 24V~ (-15% +25%)	5
OP1-OP2-OP4 outputs	B
Relay-Relay-SSR Drive	1
Triac-Triac-SSR Drive	5
Relay-Relay-Relay	9
Serial communications	C
Not fitted	0
RS 485 Modbus/Jbus SLAVE	5
Options	D
None	0
Valve drive output (no potentiometer)	2
Analogue output + Remote Setpoint	5
Valve drive output + Analogue output (retr.) + Remote Setpoint	7
Setpoint programmer - special functions	E
Not fitted	0
Start-up + Timer	2
One "8 segments" program	3
Instruction handbook	F
Italian-English (std)	0
French-English	1
German-English	2
Spanish-English	3
Front case colour	G
Dark (std)	0
Beige	1

Input type	Range scale	I	L
RTD Pt100 IEC751	-99.9...300.0 °C -99.9...572.0 °F	0	0
RTD Pt100 IEC751	-200...600 °C -328...1,112 °F	0	1
TC L Fe-Const DIN43710	0...600 °C 32...1,112 °F	0	2
TC J Fe-Cu45% Ni IEC584	0...600 °C 32...1,112 °F	0	3
TC T Cu-CuNi	-200...400 °C -328...752 °F	0	4
TC K Chromel -Alumel IEC584	0...1,200 °C 32...2,192 °F	0	5
TC S Pt10%Rh-Pt IEC584	0...1,600 °C 32...2,912 °F	0	6
TC R Pt13%Rh-Pt IEC584	0...1,600 °C 32...2,912 °F	0	7
TC B Pt30%Rh-Pt Pt6%Rh IEC584	0...1,800 °C 32...3,272 °F	0	8
TC N Nicrosil-Nisil IEC584	0...1,200 °C 32...2,192 °F	0	9
TC E Ni10%CR-CuNi IEC584	0...600 °C 32...1,112 °F	1	0
TC Ni NiMo 18%	0...1,100 °C 32...2,012 °F	1	1
TC W3%Re-W25%Re	0...2,000 °C 32...3,632 °F	1	2
TC W5%Re-W26%Re	0...2,000 °C 32...3,632 °F	1	3
0...50mV linear	Engineering units	1	4
10...50mV linear	Engineering units	1	5
mV "Custom" scale	On request	1	6
Control mode		M	
ON-OFF reverse action		0	
ON-OFF direct action		1	
P.I.D. single reverse action		2	
P.I.D. single direct action		3	
P.I.D. double action	Linear cool output	4	
	ON-OFF cool output	5	
	Water cool output	6	
	Oil cool output	7	
Output type - Single action	Output type - Double action	N	
Relay	Heat Relay, Cool Relay	0	
Digital	Heat Relay, Cool Digital	1	
Analogue	Heat Digital, Cool Relay	2	
Valve drive	Heat Relay, Cool Analogue	3	
	Heat Analogue, Cool Relay	4	
	Heat Digital, Cool Analogue	5	
	Heat Analogue, Cool Digital	6	
AL1-AL2-AL3 type and function		O-P-Q	
Disabled or (only AL3) used by Timer or related to the program		0	
Sensor break/Loop break alarm	absolute	1	
	Absolute	2	
Deviation	active high	3	
	active low	4	
Band	active high	5	
	active low	6	
Heater break by CT	active out	7	
	active in	8	
Setpoint type	active during ON output state	9	
	active during OFF output state	0	
Setpoint type		R	
Local only		0	
Local and 2 tracking stored Setpoints		1	
Local and 2 Stand-by stored Setpoints		2	
Local and Remote (if option installed)		3	
Local with trim (only with remote Setpoint)		4	
Remote with trim (if option installed)		5	
Time programmable (if option installed)		6	

If not differently specified the controller will be supplied with standard version
Model: Q3 3100-0000