

## 2051 Panelmeter for pulse sensors

- Input frequency range 0,0001 Hz..5 kHz
- Sensors: NPN, PNP, Namur, Closing contact or Pickup
- 6-digit processor-based LED display, digit height 15 mm
- Galvanically isolated output 0/4..20 mA, 0..10V
- Two alarm relays
- Pulse output for a cumulative counter
- Serial output RS-232 or RS-485
- Sensor supply 24 VDC, max. 150 mA
- Power supply 85..240VAC or 12..32 VDC/24 VAC



The panelmeter 2051 is designed for pulse sensors, whose frequency will be measured. The inputs are NPN-, PNP-, Namur -sensors, closing contact or a pickup-sensor.

The input frequency range 0,0001Hz .. 5 kHz is exceptionally wide starting with extremely low frequencies. The display is scaleable on the whole frequency range, e.g. 0-1,23 Hz can correspond to the range 0-5000 on the display. Output is freely scaleable on the basis of the display, e.g. 4-20 mA. The measuring method applied for low frequencies is to measure the time interval between two incoming pulses and for higher frequencies to measure the frequency. The display also provides a power supply of 24VDC, max. 150 mA for a sensor.

The panelmeter has two optional card slots: one for output 0/4-20 mA, 0-10V, and the other for alarms or serial output RS-485/232. Optional cards can easily be added on afterwards as well.

The alarm relay card (or I/O -card) may also be used as an output for a pulse divider. The pulse divider transmits a pulse for instance to an external counter when the pulse rate set in the divider is reached (e.g. 1 pulse/ 1000 litres).

Separate passwords can be set for access to the configuration menu and alarms. Brightness of the display is selectable. Front panel protection rating is IP65.

The panelmeter series 2000 is very flexible and easy to modify by changing input cards for different kinds of sensors, such as temperature sensors, pulse sensors, serial inputs etc. The modification does not require any calibration. The optional cards are the same for all the instruments in this product family. Each panelmeter type has its own datasheet.

Separate field enclosures can be supplied for 1 to 3 panelmeters. The 2051 is also available in the field display series, model 2800-2051.

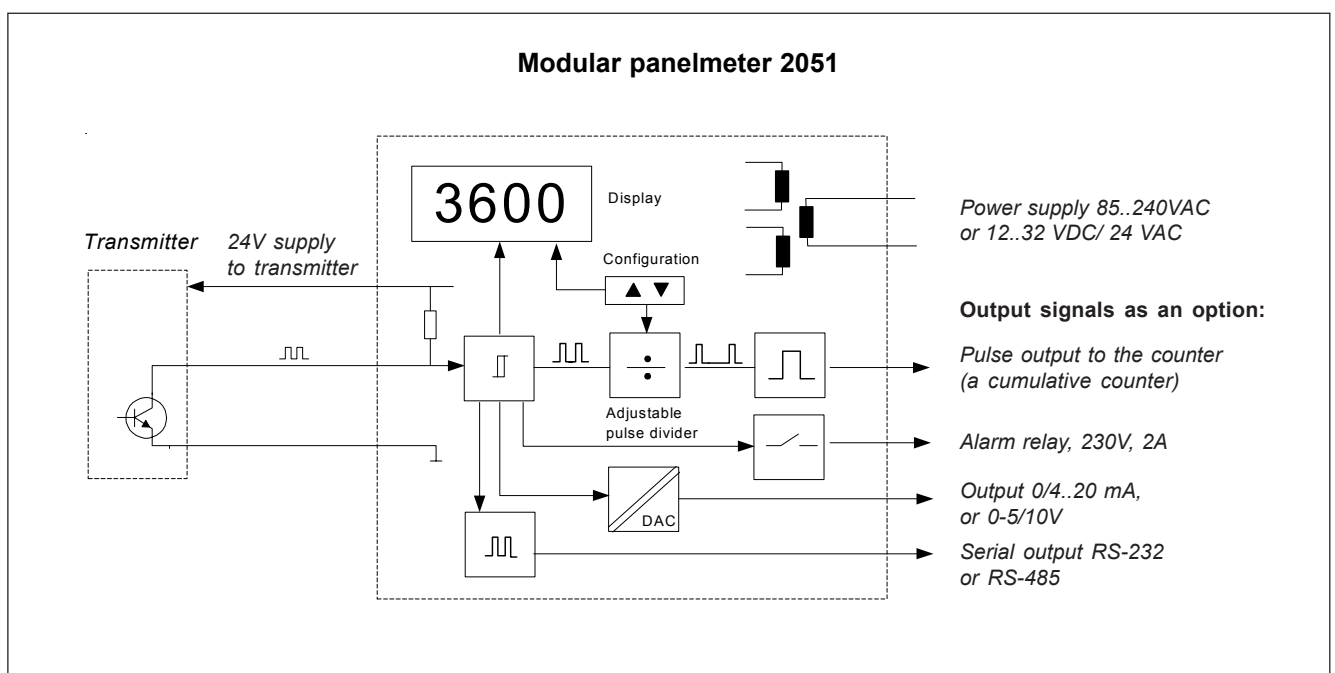

# Technical specification:

**Input frequency range:** 0,0001..5 kHz  
**Display scaling:** on the whole display range  
**Decimal point selection:** freely selectable  
**Updating time of display:** 1..2 incoming pulses  
**Sensors:** NPN, PNP, Namur, pick-up or closing contact  
input pulse 0 = <1V, 1 = 5..32V  
**Sensor supply:** 24 VDC ±5 %, max. 150 mA, isolated from power supply  
**Measuring method:** measuring the time interval between incoming pulses  
**Accuracy:** 0,01 % of span

**Output signal (optional):**  
Output 0..20 mA, 4..20 mA, max. load 1000 ohm.,  
Voltage output 0-10V (max. load 5 mA).  
Galvanic isolation from input and power supply (test voltage 2500 V, 1min.). Scaling programmable.  
DAC 12 bits, accuracy 0,05% of span.

**Serial output (optional):**  
RS-232 or RS-485 only for reading measurement values.  
Baud rate: 300...19200 baud.

**Alarms (optional):**  
Two alarm levels freely adjustable on the front panel. Choice of direction for relay function.  
Relay contacts max. 230 VAC, 2A (2000-REL2).  
An alternative to the pulse output.

**Pulse output (optional):**  
Divider range 1..64000  
Output pulse width 1..100 ms  
I/O card max. 60 V, 0,5 A  
An alternative to the alarm relay for frequencies > 1 Hz.

**General:**  
Display 6 digits, bright red (or green) LED  
digit height 14,5 mm, brightness selectable  
digital, freely adjustable  
Case material plastic, colour black  
Operating temperature -10..+60°C  
Terminals removable, wire 2,5 mm<sup>2</sup>  
Power supply 85..240 VAC or 12..32 VDC/24 VAC  
Front panel protection IP65 with a rubber gasket  
Weight 240 g

## How to order: 2051-OUT-REL2-230VAC

Type  
Output  
Alarm card  
Power supply  
85..240VAC  
or 12...32 VDC/24 VAC

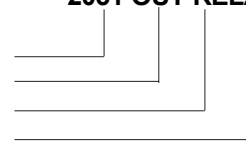

**Optional cards (2 options possible at a time):**  
Output card 2000-OUT  
Alarm card, 2 relays 2000-REL2  
I/O card (alarm) 2000-I/O  
Serial output, RS-232/485 2000-RS  
(When ordering a panelmeter, the "2000" of the cards is left out.)

The panelmeter is also available with a green LED display: please specify 2051GR in the order code.

## Connection and dimensions:

### NPN-input

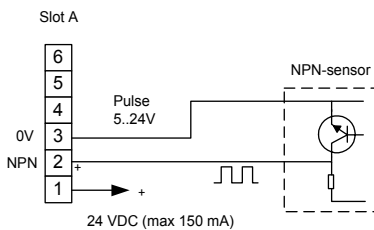

### PNP-input

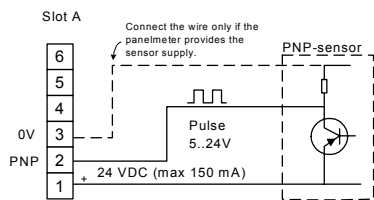

### Closing contact

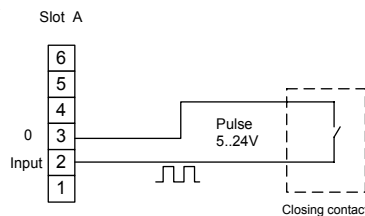

### Pick-up input

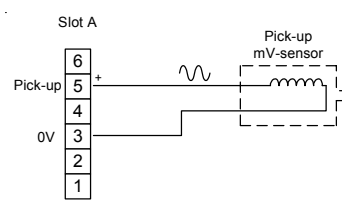

### Namur-input

