

Signal Converters & Isolators

Threshold Relay PXL-10



DESCRIPTION

A threshold relay for the monitoring or control of common types of process signals. The process signal to be monitored is selected on the front panel and the threshold value is also adjusted via a setpoint potentiometer on the front of the relay. As the input signal attains the threshold plus the hysteresis the output relay energises. When the input signal drops and passes the threshold, minus hysteresis, the relay de-energises. The hysteresis is adjustable on the front, $\pm 0,5 - 20\%$.

By strapping 2 terminals, the relay can be inverted.

A red LED indicates if the relay is energised.

There is also a latch function where the relay after energising will remain energised, regardless of input, until the latch jumper or the operating voltage is disconnected. Typically used in safety circuits.

Features

- Input 0 - 5V/0-10V/-10-+10VDC/0-20/4-20mA in one version.
- Adjustable setpoint.
- Hysteresis adjustable $\pm 0,5-20\%$.
- Automatic locking (Latch).
- Inversion of relay function.
- Output SPDT.
- Operating voltage 24VDC, 24/115VAC or 24/230VAC.

VERSIONS/ORDERING CODES

Type:
Threshold relay

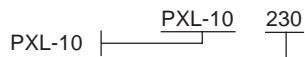

Supply voltage

- 24V DC
- 115V / 24V AC
- 230V AC / 24V AC



OPERATION

Output signal

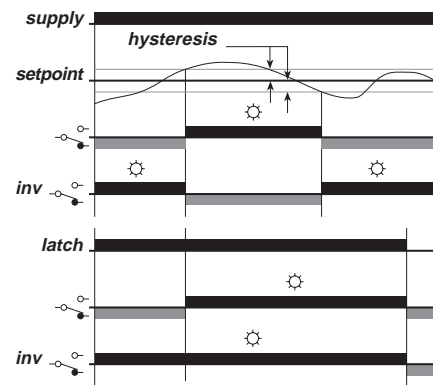

MECHANICAL DIMENSIONS

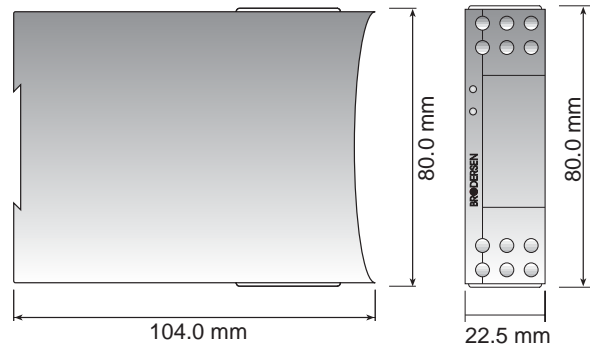

TECHNICAL DATA

Input:

Input signal	Impedance	$U_{max} = 50V_{p-p}$
0-5V DC	>100kOhm	
0-10V DC	>100kOhm	$I_{MAX} = 50mA$
-10-+10V DC	>100kOhm	
0-20mA DC	50 Ohm	
4-20mA DC	50 Ohm	

Selected via switches on the front panel.

Hysteresis: $\pm 0,5-20\%$ of range, adjustable.
Response time: Time constant (τ = approx. 0,3s, worst case of response time max. 5xt).

Upper critical frequency 30 Hz.

Output:

SPDT relay:	Contact material, AgNi 0,15 with hardened gold plating Au.
Max load AC:	8A/240V AC ($\cos \varphi=1$) Max. breaking capacity 2000VA. Inductive load. See fig. 1.
Max load DC:	8A/24V DC. Max. breaking capacity 50-270W. See fig. 2.
Max. in rush current:	15A (max. 4s/duty cycle less than 10%)
Min. in rush current:	10mA, 24V DC.
Frequency :	Max. 1000 operations pr. hour.
Life span:	Mech. Min. 3×10^7 operations. Elect. Min. 1×10^9 operations with full load.
Delay:	<20ms.

Supply voltage:

Versions:	924 = 24V DC (20,4-27,6)V DC 115 = 24/115V AC (20,4-27,6/98-132)V AC 230 = 24/230V AC (20,4-27,6/196-264)V
-----------	--

AC

Net frequency:	45-65Hz
Consumption:	AC; 3VA DC; 2W

General data:

Ambient temperature: -20 to 55°C.
Storage temperature: -40 to 80°C.
Mounting: 35mm DIN-rail (EN50022).
Terminals: Screw terminals with dual compartment.
Terminal screws are combined crosshead/slotted.
Up to 2 x 2,5mm² wire (2 x 1,5mm² inc. ferrule).
Recommended torque, 0,5Nm., max. 0,7 Nm. (VDE0609-1).
Terminal identification in accordance with DIN46199/EN50005.

Indicators:	Green LED = operating voltage. Red LED = relay switched on.
Protection:	IP20.
Electric isolation:	3,75kVAC (1 min.) between input, supply and relay output (EN60950).
Housing:	Noryl (GE), UL94V1.
Terminal block:	Noryl (GE), UL94V0.
Weight:	180 g.

WIRING DIAGRAM

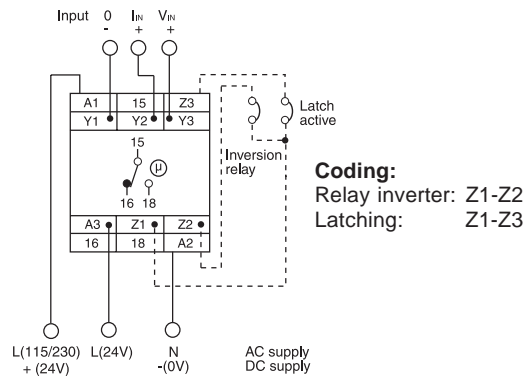

SPECIFICATIONS:

PXL-10 is designed and developed with regard to relevant specifications:

- EN60204-1 / VDE0113 electrical material on machines.
- VDE0110 / IEC664 Isolation specifications/creepage and clearance distances.
- Electrical safety in accordance with EN61010.
- IEC414 Safety regulations for control and monitoring equipment.
- EMC: Emission EN50081-1
Immunity EN50082-2
- Humidity in accordance with IEC68-2-3; RH=95%, 40°C.
- Vibration in accordance with IEC68-2-6:
- Shock when mounted, in accordance with IEC68-2-27.

PXL-10 is CE-marked in accordance with EMC-and the Low Voltage Directive.

OUTPUT LOAD DIAGRAMS

Fig. 1

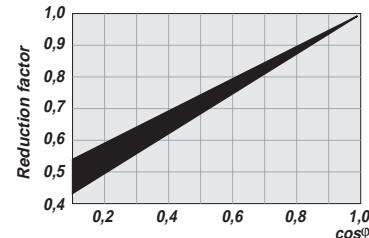

Fig. 2

